

ODU MINI-SNAP[®] SERIES L,K,B

Assembly instructions



ASSEMBLY INSTRUCTIONS

General notes	<u>03</u>
Series L straight plug and in-line receptacle	<u>05</u>
Series L right-angled plug	<u>09</u>
Series L Super Shorty	<u>13</u>
Series K straight plug and in-line receptacle	<u>19</u>
Series K right-angled plug.....	<u>23</u>
Series B straight plug and in-line receptacle	<u>28</u>
Series B right-angled plug.....	<u>32</u>

General notes

Recommended stripping length

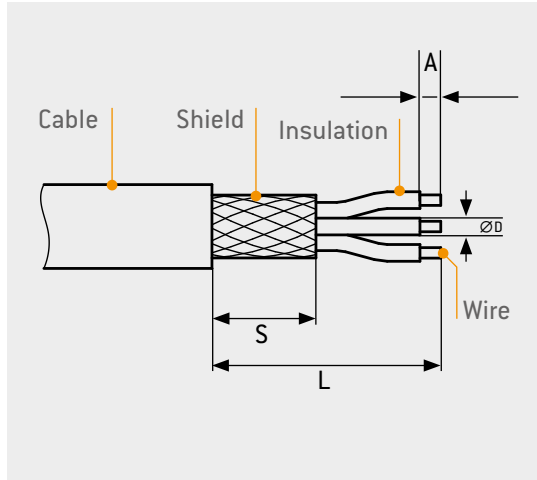

Cable stripping length L in mm

	Size	Straight		Right-angled	
		Solder	Crimp	Solder	Crimp
Series L	00	5	–	11	–
	0	9	14	8	14
	1	9	15	13	24
	2	11	20	15	27
	3	16	26	19	31
4	22	35	–	–	
Series K	0	7	8	18	25
	1	7	12	25	27
	2	9	12	28	32
	3	15	17	30	30
	4	15	–	–	–
Series B	0	7	8	15	20
	1	9	13	25	30
	2	10	14	30	35
	3	14	18	30	40
Super Shorty	0	15	15	–	–
	1	12	16	–	–
	2	11	16	–	–

Shield stripping length S in mm

Size	Stripping length		
	Series L	Series K	Series B
00	3.5	–	–
0	–	4.0	–
1	–	4.0	–
2	5.0	–	–
3	6.0	–	–
4	7.0	4.0	–
Super shorty (all sizes)		–	8.0

Strand stripping length A in mm

Solder		Crimp	
AWG	Stripping length	AWG	Stripping length
12	4.5 + ØD	14–18	6.7
14 18 20	3.3 + ØD	18–20	5.0
22 26	2.8 + ØD	20–24	4.7
28	2.3 + ØD	22–26	
		28–32	

Tolerances (in mm)

Lenghts	Tolerance cable sheath L
up to 20	± 1.0
21 to 50	± 2.0
Lenghts	Tolerance wire A
up to 5	± 0.5
6 to 10	± 1.0
Lenghts	Tolerance shield S
to 10	± 1.0

ATTENTION!

Please note that for some connectors the scope of delivery may differ from the illustration in these general installation instructions. Therefore, these installation instructions must always be used together with the drawing of the respective plug connector. Deviating information on the drawing always has priority. Click here for the [Product-Finder](#)

General notes

Tightening torque moment in Nm (Back nut / -screw & shielding sleeve)

Size	00	0	1	2	3	4
Back nut (Straight plug and in-line receptacle)	0,25 ± 0.1	0.6 ± 0.1	1.0 ± 0.2	2.0 ± 0.4	3.5 ± 0.7	3.5 ± 0.7
Back-screw (Right-angled plug)		0.3 ± 0.1	0.4 ± 0.1	0.9 ± 0.2	1.3 ± 0.3	2.0 ± 0.4
Shielding sleeve (Super Shorty)	–	0.6 ± 0.1	1.0 ± 0.2	2.0 ± 0.4	–	–

The recommended tightening torques depend on the cable diameter.

Tools / Accessories

ODU wrench and crimping tools see ODU MINI-SNAP® catalog series L,K,B section accessories and tools.

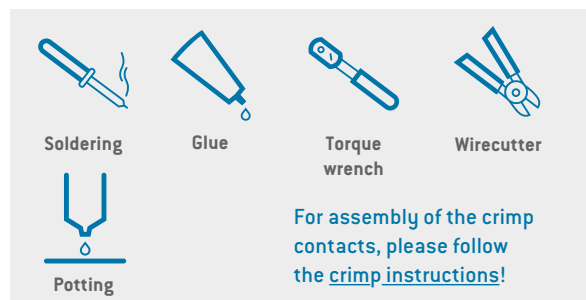

Tightening torque moment in Nm (receptacle)

Thread receptacle	Tightening torque moment
M7 x 0.5	0.8 ± 0.2
M9 x 0.5	1.3 ± 0.3
M10 x 0.5	1.7 ± 0.4
M11 x 0.5	2.0 ± 0.4
M11 x 0.75	
M12 x 1	2.5 ± 0.5
M14 x 1	3.0 ± 0.6
M15 x 1	4.0 ± 0.8
M16 x 1	4.5 ± 0.9
M17 x 1	5.5 ± 1.1
M18 x 1	6.0 ± 1.2
M20 x 1	6.5 ± 1.3
M24 x 1	10.0 ± 2.0
M25 x 1	
M30 x 1	17.0 ± 3.4

Recommended glue for the back nut

Loctite® 243™
ODU part number 890.204.000.030.031

Recommended cleaning agent:
Isopropyl alcohol

All the connectors shown here are connectors without breaking capacity (COC) according to IEC 61984:2008 (VDE 0627:2009-11).

Safety instructions

(For applications which do not run within the safety extra-low voltage (SELV))

According to IEC 60364-4-41:2005 + A1:2017 (DIN VDE 0100-410:2018-10), two independent protective measures must be combined to create appropriate safety precautions against electric shock: one basic protective measure and one fault protective measure.

ATTENTION!

For voltages > 50 V AC and > 75 V DC, an additional protective measure (fault protective measure) to the basic insulation (basic protective measure) given by our connector is required according to IEC 60364-4-41:2005 + A1:2017 (DIN VDE 0100-410:2018-10). The standard describes in more detail which protective measures are suitable and permitted.

In this case the following must be observed for our connectors:

- The live side must be the socket-insert side
- It is mandatory to glue the back nut with the recommended adhesive

Overview of series L straight plug and in-line receptacle

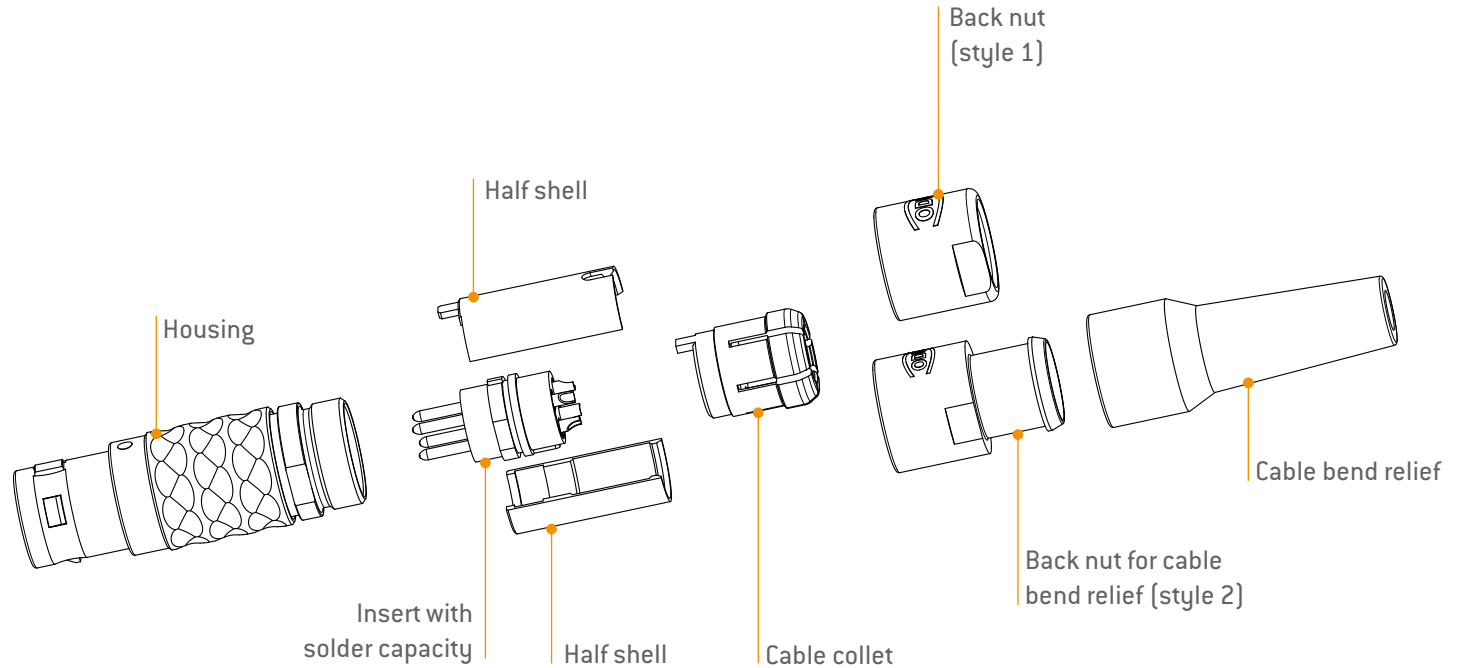

Assembly of series L straight plug and inline-receptacle

Step 1

- ▶ Slide back nut and cable collet (and possibly cable bend relief) over the cable.

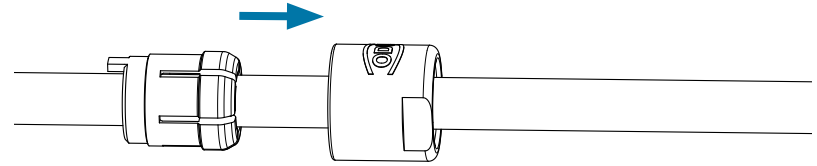

Step 2

- ▶ Strip cable and wire according to reference table ([see page 03](#)).

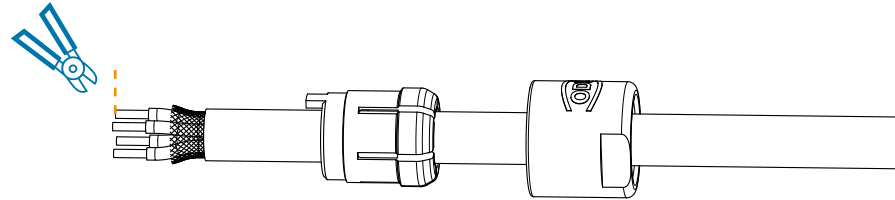

Step 3

- ▶ Pre-tin strands.

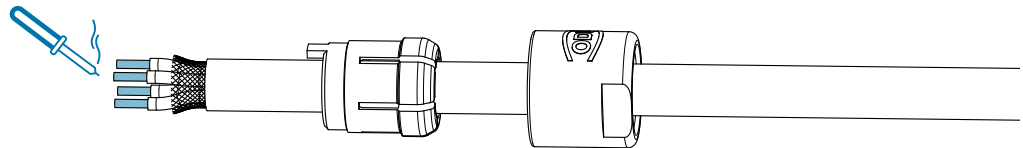

Step 4

- ▶ Solder the wires according to contact arrangement.

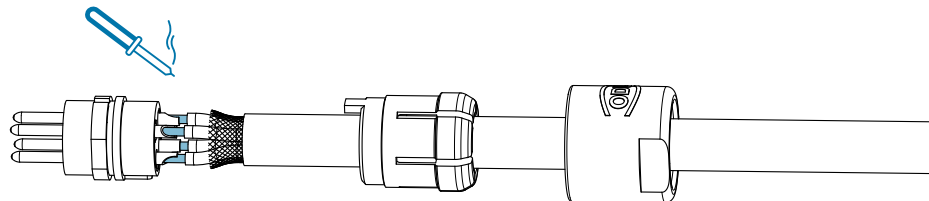

Step 5

- ▶ Bend cable shield outwards, assemble half shells.

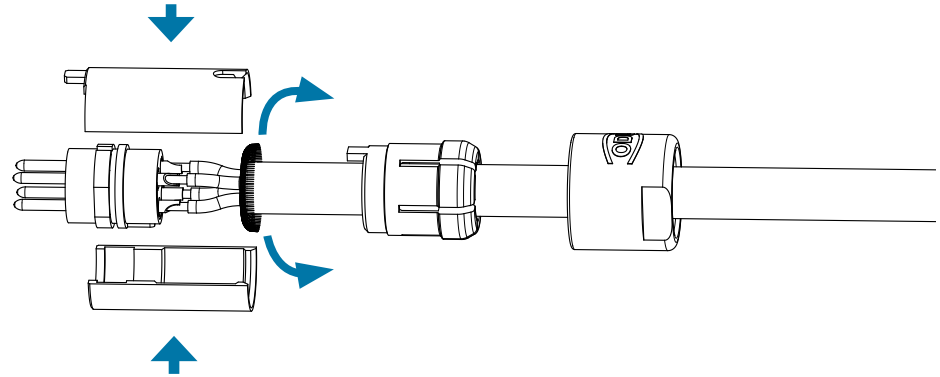

Step 6

- ▶ Slide the cable collet against the half-shells and clamp the shield (A) between it.

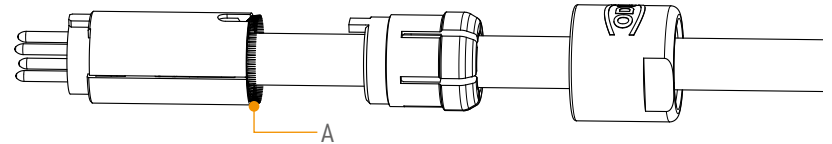

Step 7

- ▶ Insert the complete assembly into the connector housing while respecting the guidings (B). If necessary, secure thread (C) with adhesive ([see page 04](#)).

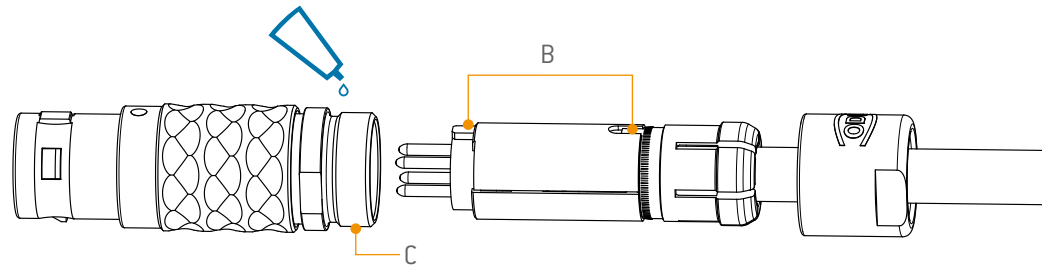

Step 8

- ▶ Screw back nut on the assembled plug, counterhold by means of the **spanner** and hold against with ODU spanner wrench.

ATTENTION!

Consider tightening torque ([see page 04](#)).

The assembly is finished.

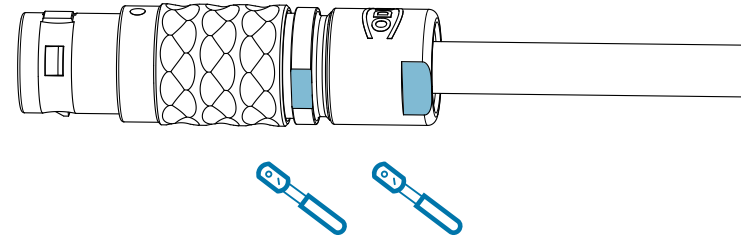

Overview of series L right-angled plug

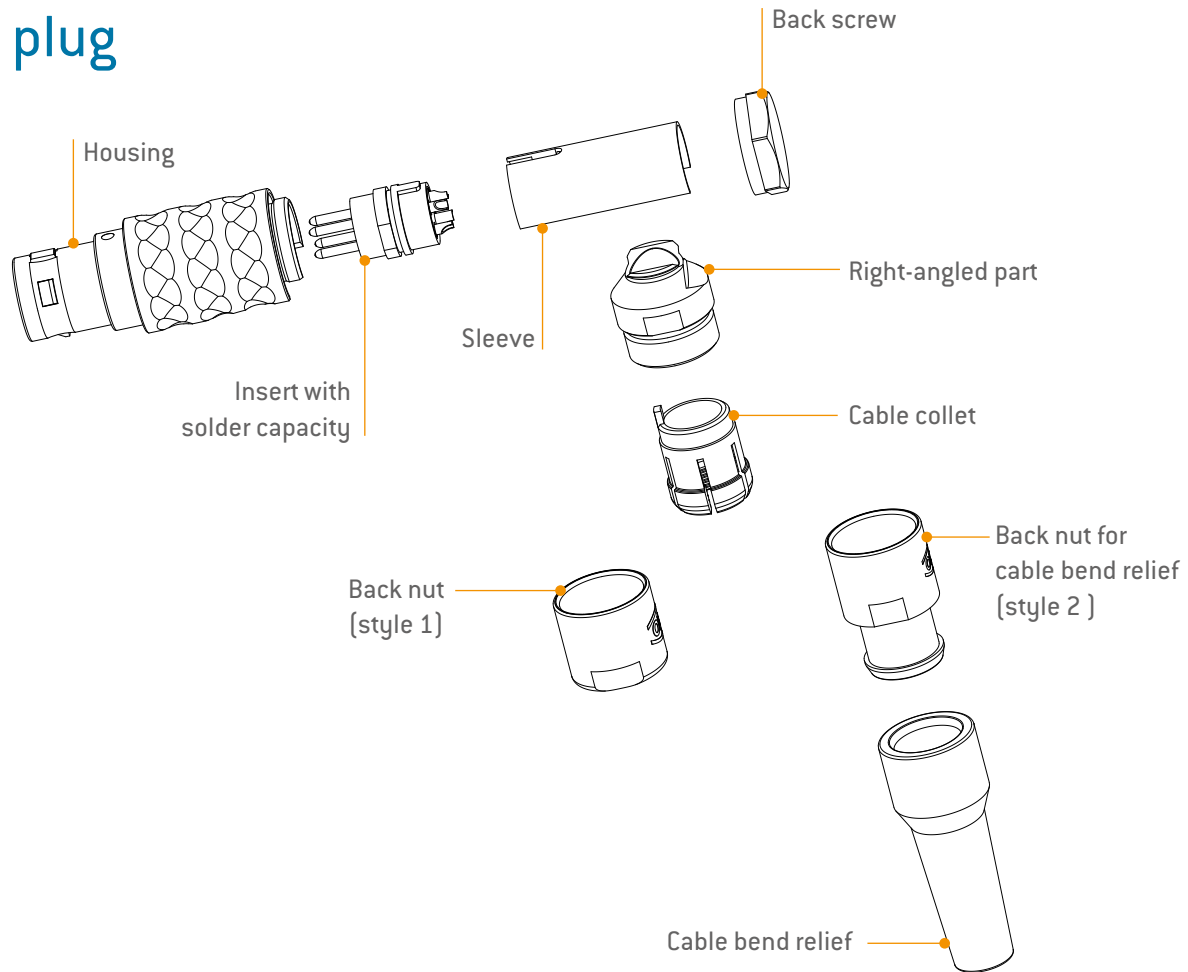

Assembly of series L right-angled plug

Step 1

- ▶ Slide back nut, cable collet, right-angled part (and possibly cable bend relief) over the cable.

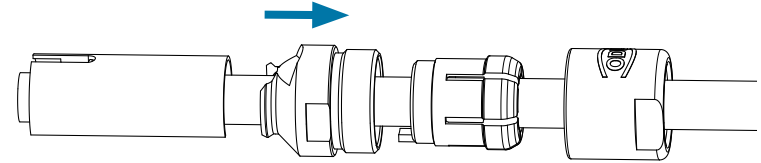

Step 2

- ▶ Strip cable and wire according to reference table ([see page 03](#)).

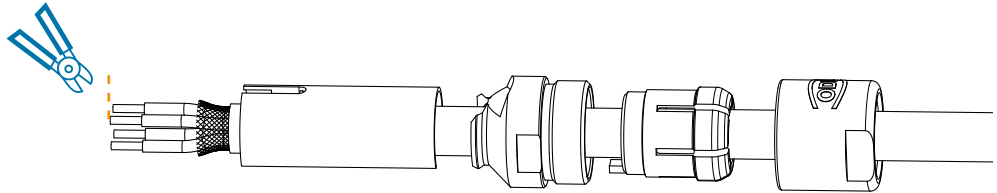

Step 3

- ▶ Pre-tin strands.

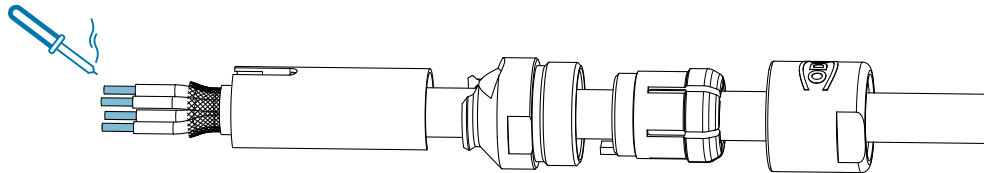

Step 4

- ▶ Solder the **wires** according to contact arrangement.

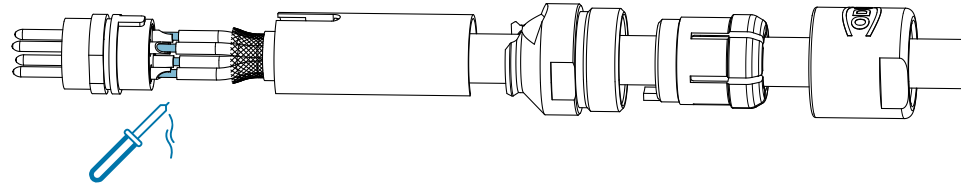

Step 5

- ▶ Pull cable back and bend 90° down. Spread the cable **shield** (A) over collet ring. Slide sleeve over insulator.

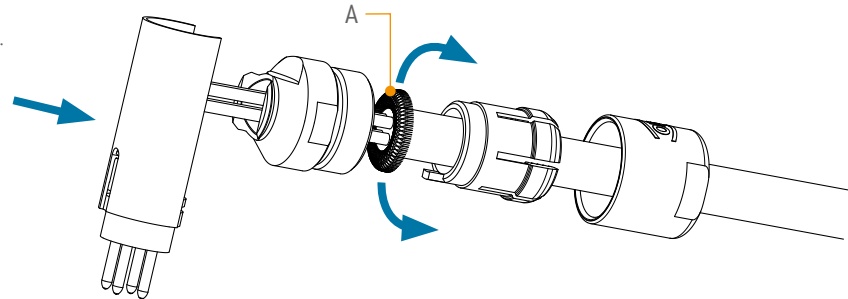

Step 6

- ▶ Slide the cable collet against the right-angled part and clamp the shield between it. If necessary, secure **thread** (B) with adhesive ([see page 04](#)).

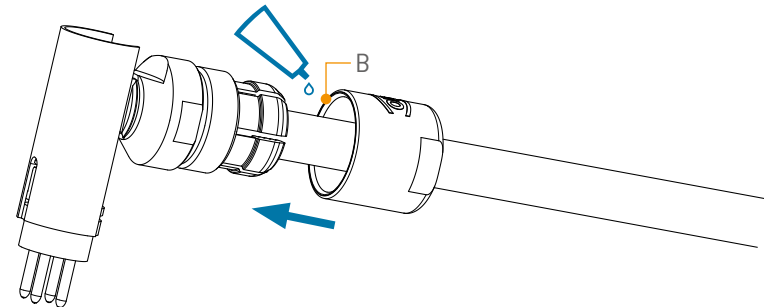

Step 7

- ▶ Insert the complete assembly into the connector housing while respecting the **guidings** (C).
Screw **back nut** (D) on the right-angled part and hold against by means of the **spanner** (E) with the ODU torque wrench.

ATTENTION! Consider tightening torque ([see page 04](#)).

If necessary, secure **thread** (F) with adhesive ([see page 04](#)).

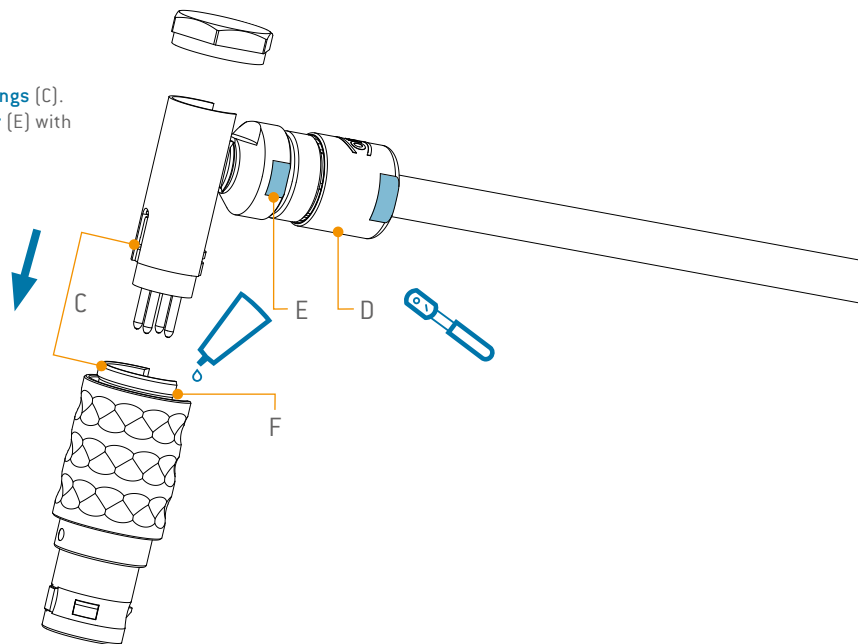

Step 8

- ▶ Mount back screw on the assembled plug and counterhold by means of the **spanner** at (G) with ODU torque wrench.

ATTENTION! Consider tightening torque ([see page 04](#)).

The assembly is finished.

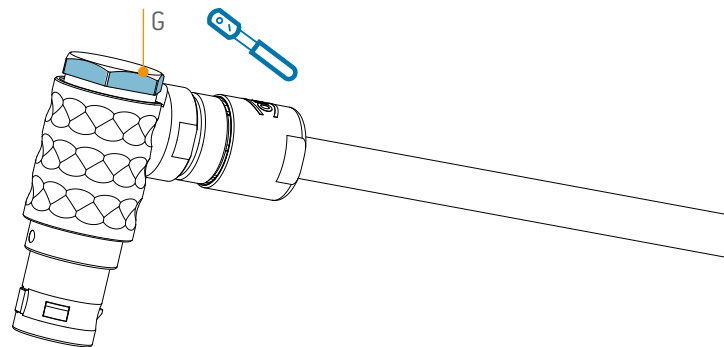

Overview series L

Super Shorty

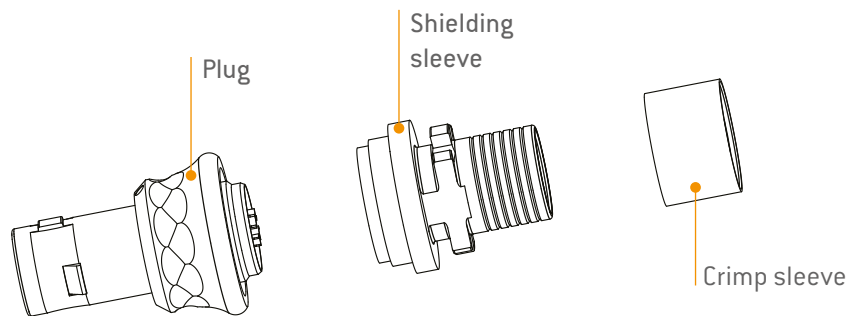

Assembly of series L Super Shorty

Step 1

- ▶ Slide crimp sleeve and shielding sleeve (and possibly shrink tube) over the cable. The crimp sleeve is not needed if a metal band is used for fastening the shield to the shielding sleeve.

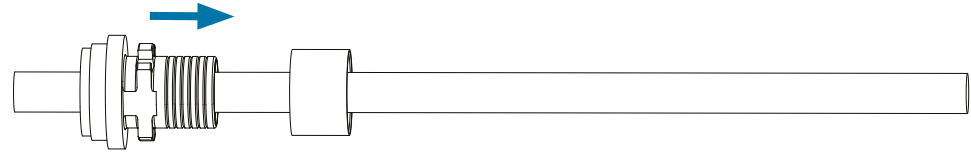

Step 2

- ▶ Strip cable and wire according to reference table ([see page 03](#)).

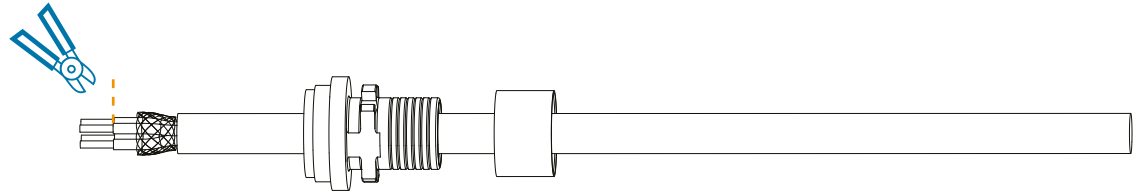

Step 3

- ▶ Fold back the **shield** (A) and, if necessary, use fastening tape to fasten it temporarily to the cable jacket. **Pre-tin** strands.

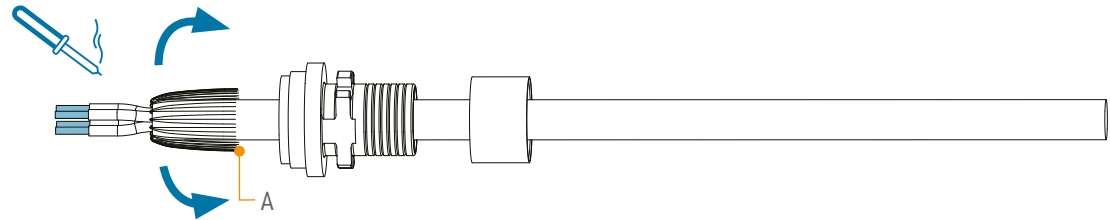

Step 4

► Solder the **wires** according to contact arrangement.

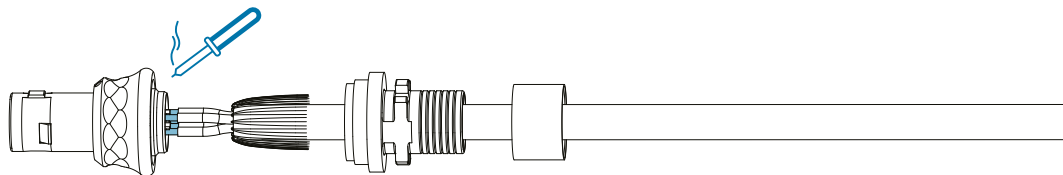

Step 5

► Secure **thread** [B] with adhesive ([see page 04](#)).

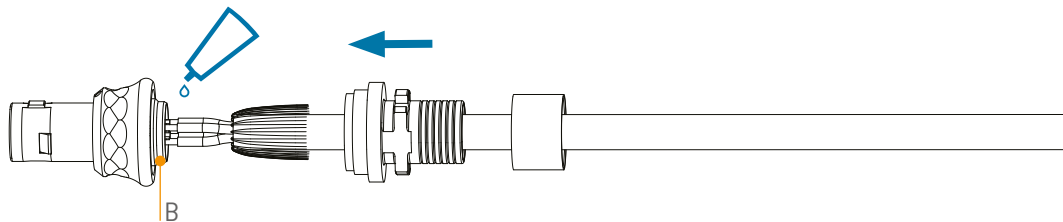

Step 6

► Screw **shielding sleeve** (C) flush onto the assembled plug, counterhold by means of the ODU assembly tool and tighten with the ODU spanner wrench.

ATTENTION !

Consider tightening torque ([see page 04](#)).

Assembly tools Super Shorty	
Size	Order number
0	750.240.103.700.000
1	751.240.103.700.000
2	752.240.103.700.000

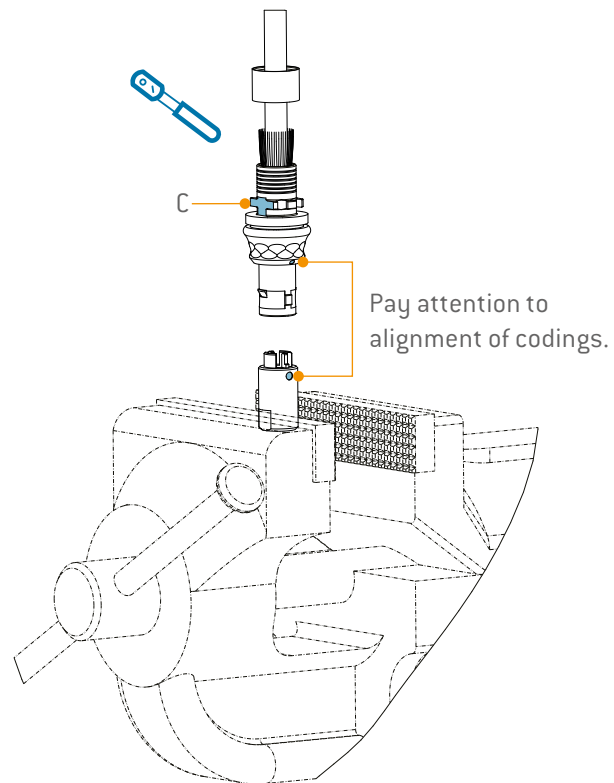

Step 7

- Remove the fastening tape and lay the **shield braid** (D) onto the shielding sleeve.

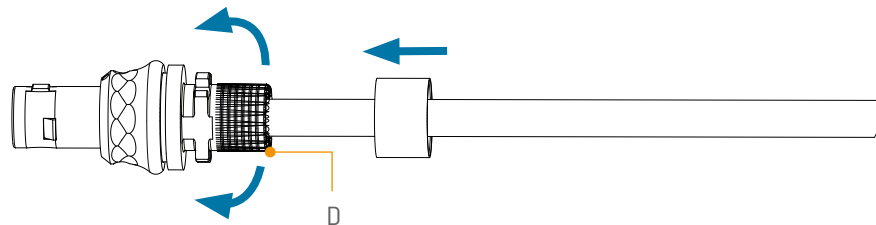

Step 8

- First fasten the shield braid to the shielding sleeve by means of crimping or by using a metal band. Afterwards pour potting compound into the termination area.

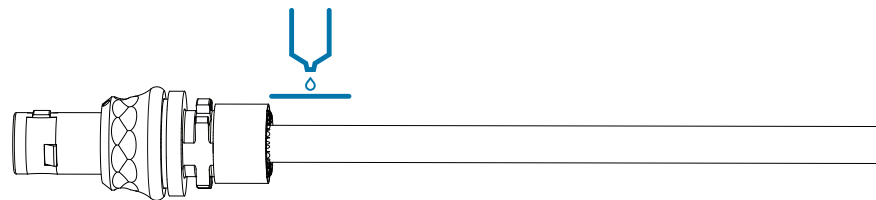

To connect the shielding with the shielding sleeve, using a crimp sleeve.

Crimping tool	
Size	Order number
0-2	080.000.026.000.000

Crimp insert	
Size	Order number
0	080.000.026.700.000
1	080.000.026.701.000
2	080.000.026.702.000

To connect the shielding with the shielding sleeve, using a Band-It band.

Band-It tool	
Size	Order number
0-2	080.000.058.000.000

Tie-Dex Micro Band	
Size	Order number
0-2	921.000.004.000.248

Step 9

► Bend relief: This can be implemented by means of overmolding or by using a shrink tube.

The assembly is finished.

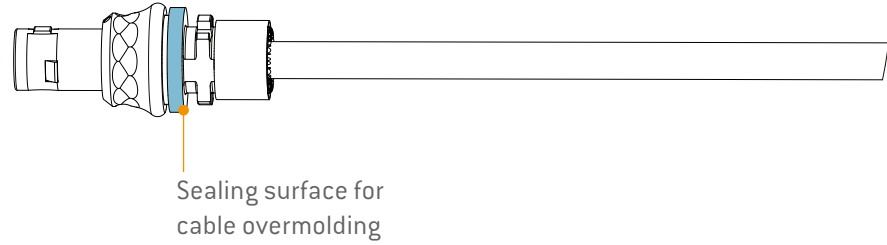

Overview of series K straight plug and in-line receptacle

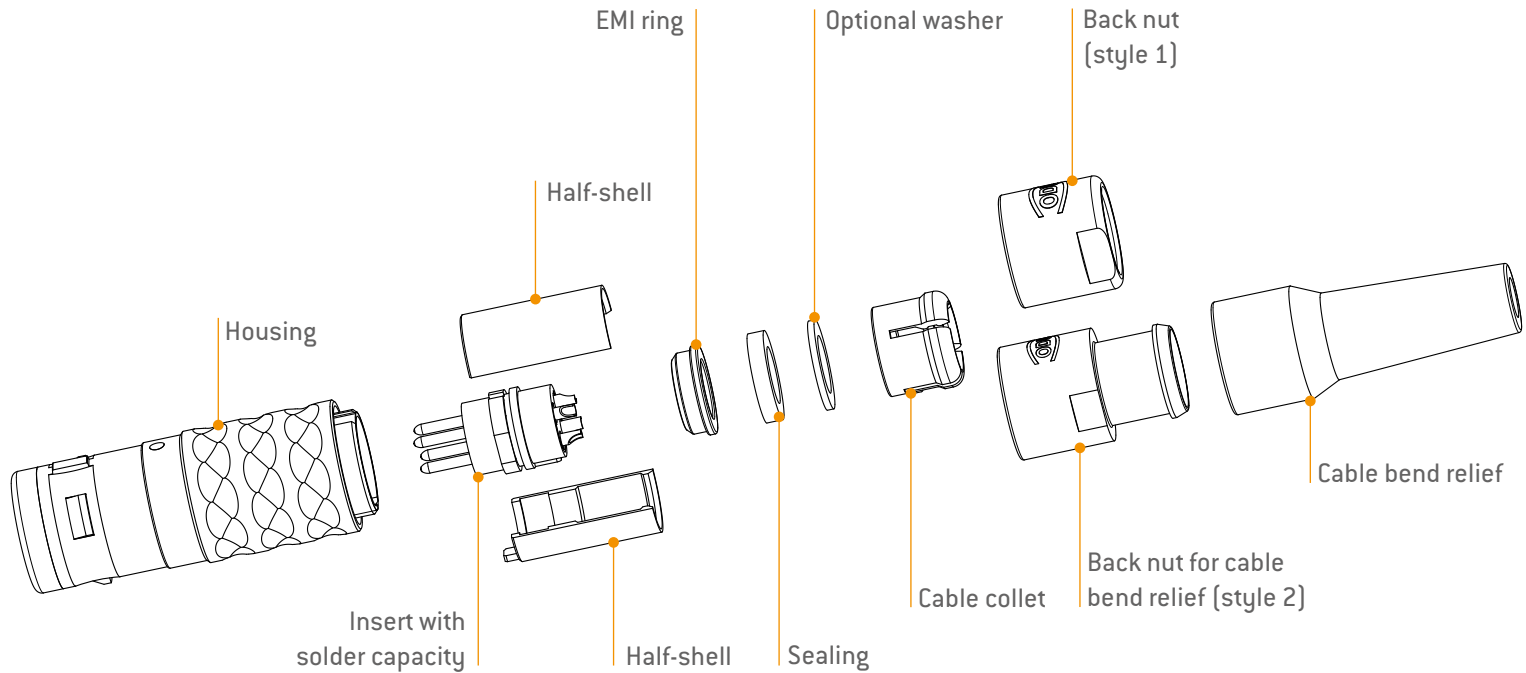

ATTENTION!

In sealed versions, plugs and cables must always be matched to each other, so we need detailed information about the cable you are using.

Assembly of series K straight plug and inline-receptacle

Step 1

- ▶ Slide back nut, cable collet, washer, sealing, EMI ring (and possibly cable bend relief) over the cable.

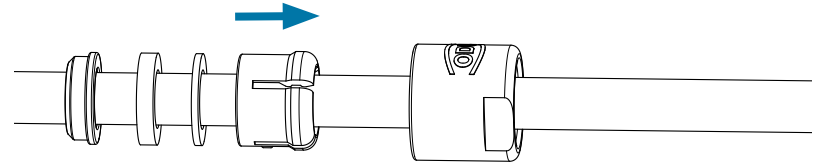

Step 2

- ▶ Strip cable and wire according to reference table ([see page 03](#)).

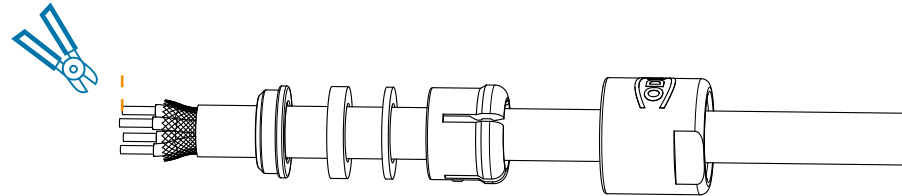

Step 3

- ▶ Pre-tin **strands**.

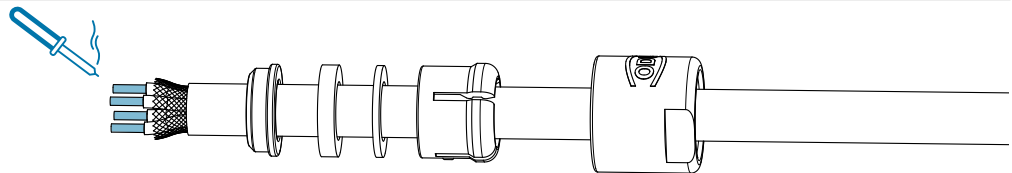

Step 4

- ▶ Solder the **wires** according to contact arrangement.

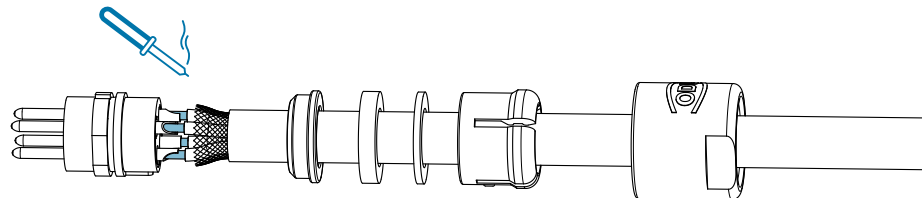

Step 5

- ▶ Bend cable shield outwards, assemble half shells.

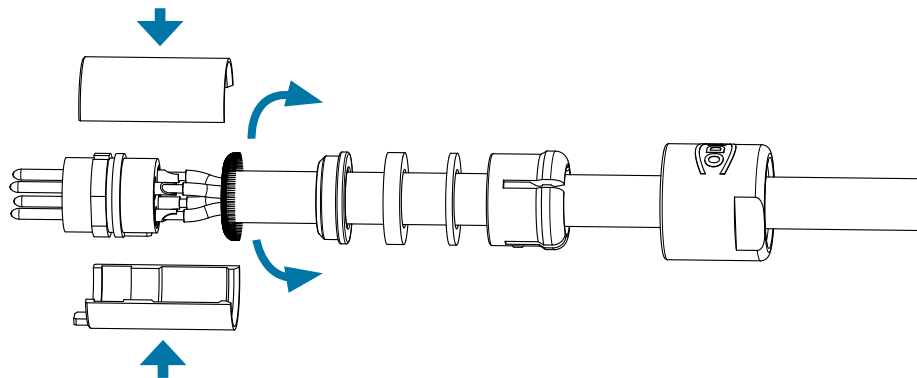

Step 6

- ▶ Slide cable collet, washer, sealing, and EMI ring against the half-shells and clamp the **shield** [A] between it.

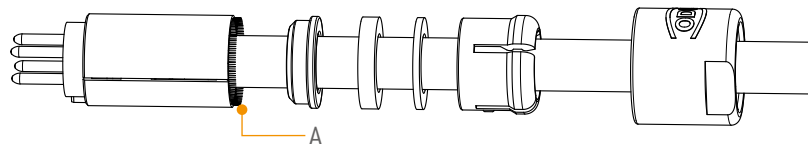

Step 7

- ▶ Insert the complete assembly into the connector housing while respecting the **guidings** [B]. If necessary, secure **thread** [C] with adhesive [[see page 04](#)].

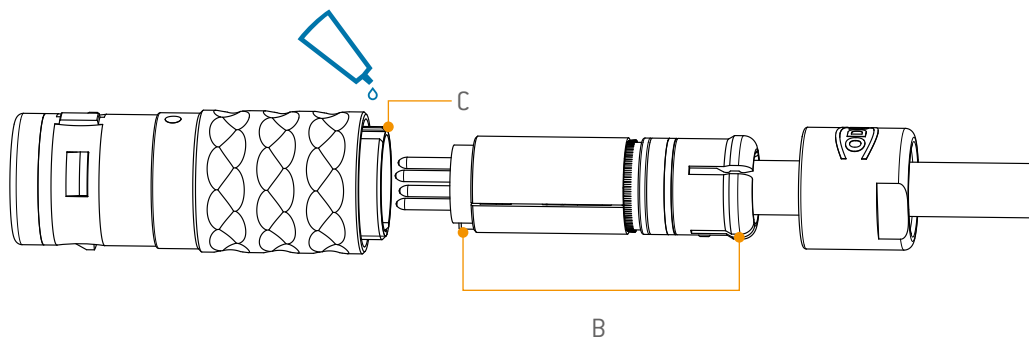

Step 8

- ▶ Screw back nut on the assembled plug and tighten by means of the **spanner wrench**. Counterhold with the **assembly tool [A]**

ATTENTION!

Consider tightening torque ([see page 03](#)).

The assembly is finished.

Assembly tools series K	
Size	Order number
0	080.000.055.631.100
1	080.000.055.631.101
2	080.000.055.631.102
3	080.000.055.631.103
4	080.000.055.631.104

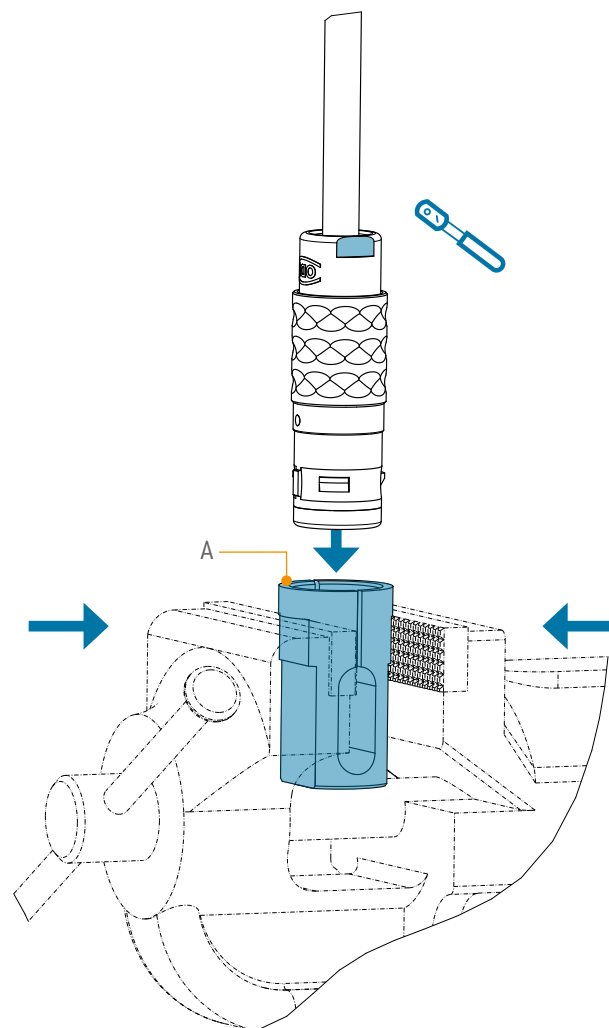

Overview of series K right-angled plug

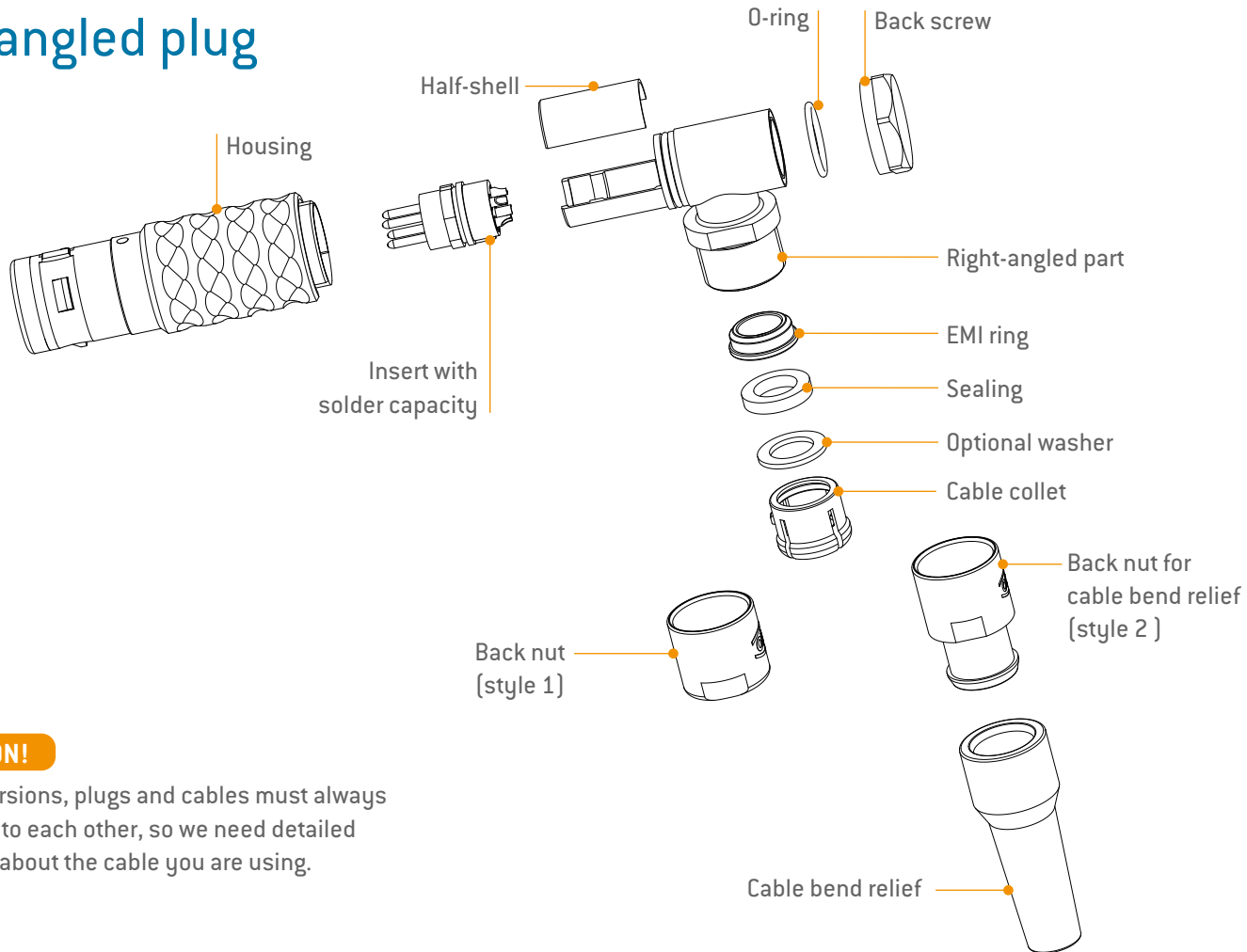

ATTENTION!

In sealed versions, plugs and cables must always be matched to each other, so we need detailed information about the cable you are using.

Assembly of series K right-angled plug

Step 1

- ▶ Slide back nut, cable collet, washer, sealing, EMI ring, right-angled part (and possibly cable bend relief) over the cable.

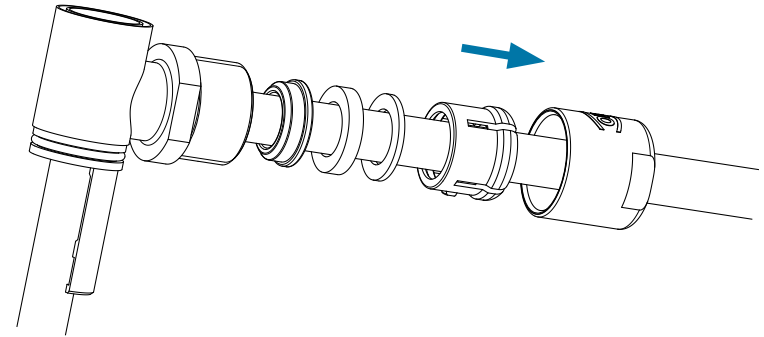

Step 2

- ▶ Strip cable and wire according to reference table ([see page 03](#)).

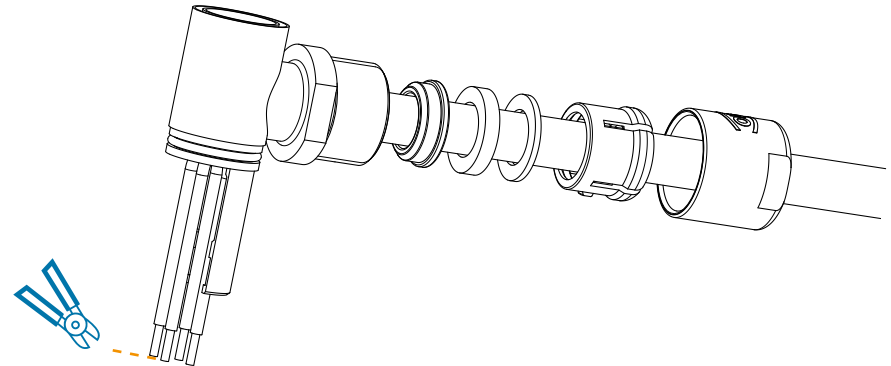

Step 3

- ▶ Pre-tin **strands**.

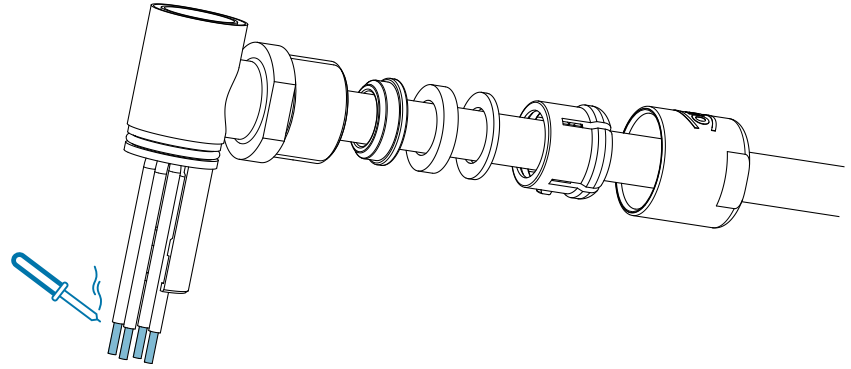

Step 4

- ▶ Solder the **wires** according to contact arrangement.

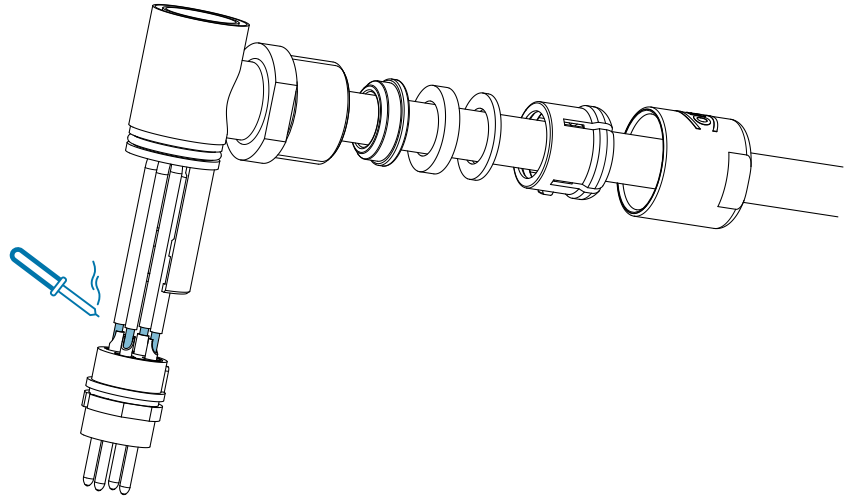

Step 5

- Pull cable back and spread the **shield** (A) over EMI ring. Slide half-shell over insulator. If necessary, secure **thread** (B) with adhesive ([see page 04](#)).

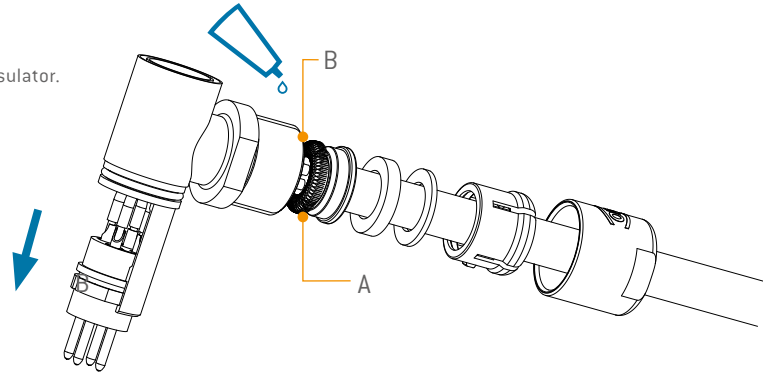

Step 6

- Slide the cable collet, washer, sealing and EMI ring against the right-angled part and clamp the shield between it. Screw **back nut** (C) on the right-angled part and counterhold by means of the **spanner** at (D) with ODU torque wrench.

ATTENTION!

Consider tightening torque ([see page 04](#)).

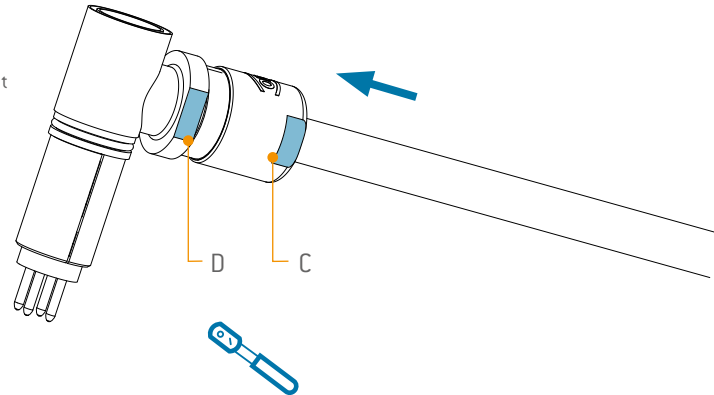

Step 7

► Insert the complete assembly into the connector housing while respecting the **guidings** (E).

ATTENTION! Consider tightening torque ([see page 04](#)).

If necessary, secure **thread** (F) with adhesive ([see page 04](#)).

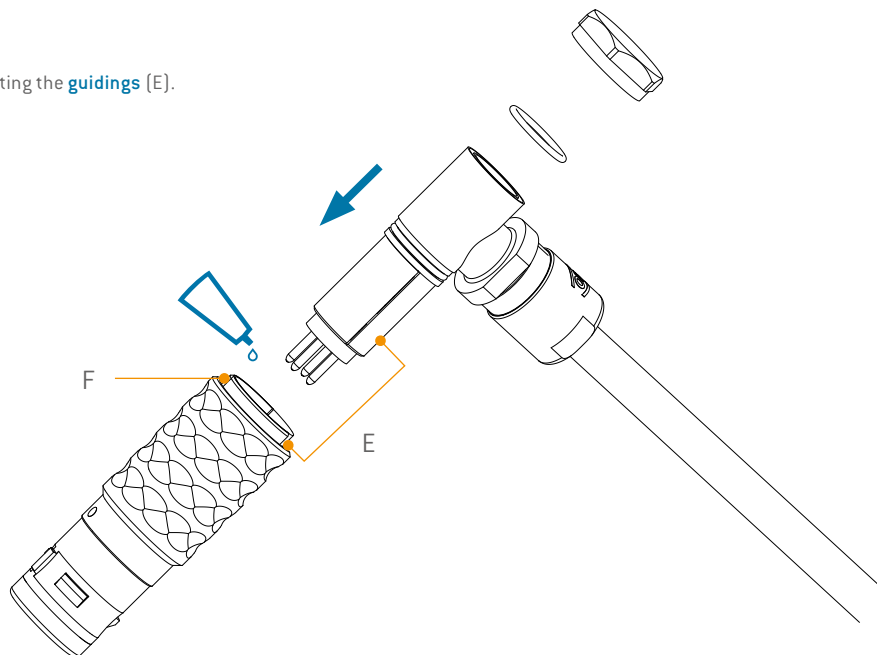

Step 8

► Mount back screw on the assembled plug and counterhold by means of the **torque wrench** at (G) with ODU spanner wrench.

ATTENTION! Consider tightening torque ([see page 04](#)).

The assembly is finished.

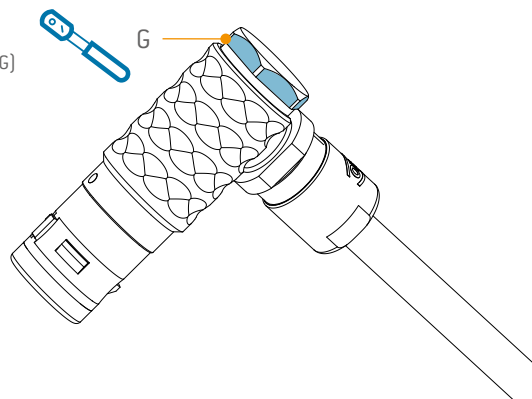

Overview of series B straight plug and in-line receptacle

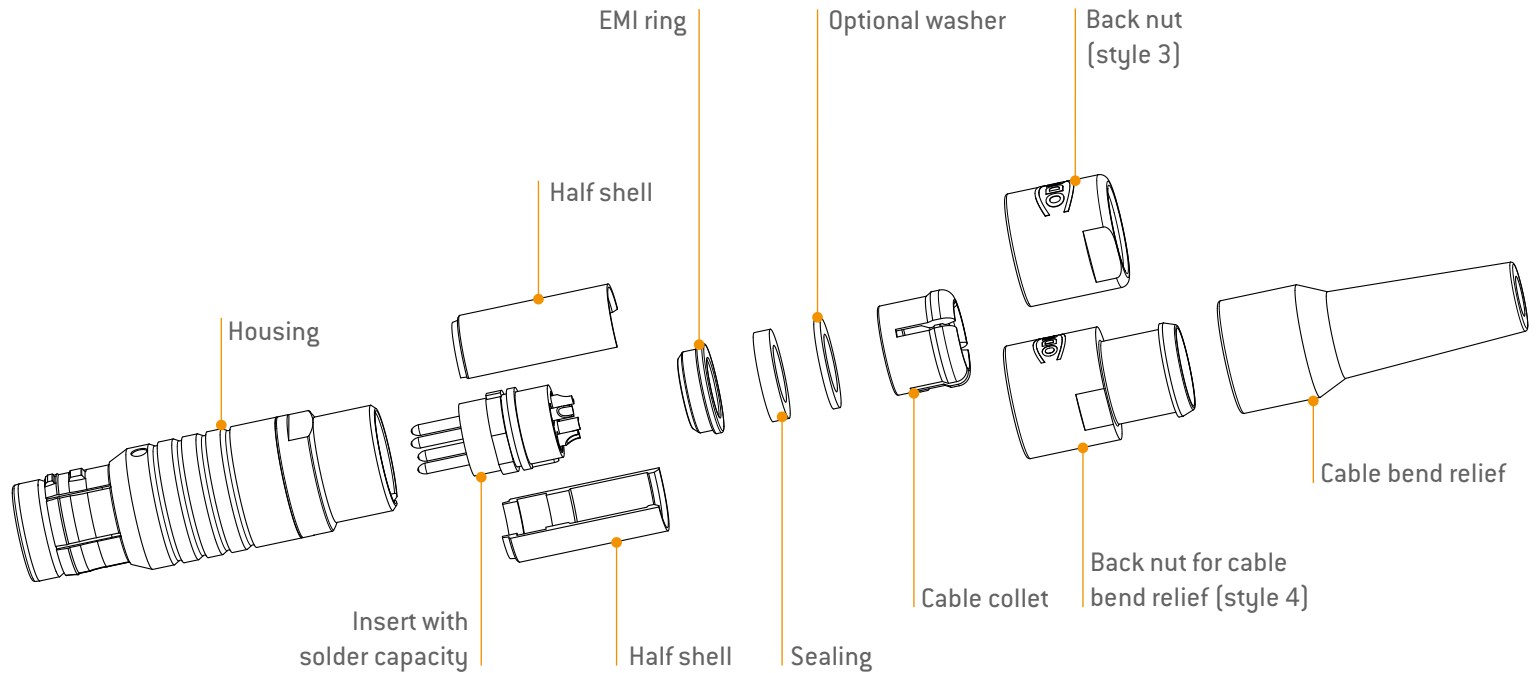

ATTENTION!

In sealed versions, plugs and cables must always be matched to each other, so we need detailed information about the cable you are using.

Assembly of series B straight plug and in-line receptacle

Step 1

- ▶ Slide back nut, cable collet, washer, sealing and EMI ring (and possibly cable bend relief) over the cable.

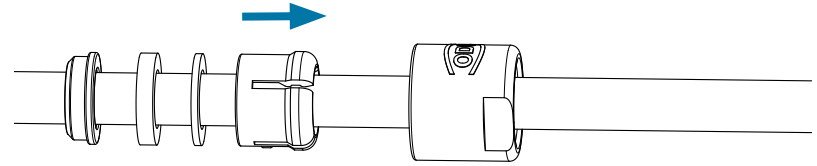

Step 2

- ▶ Strip cable and wire according to reference table ([see page 03](#)).

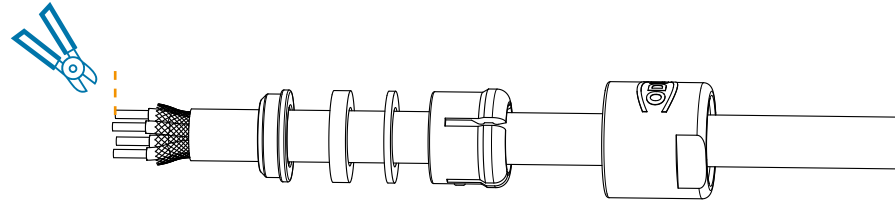

Step 3

- ▶ Pre-tin **strands**.

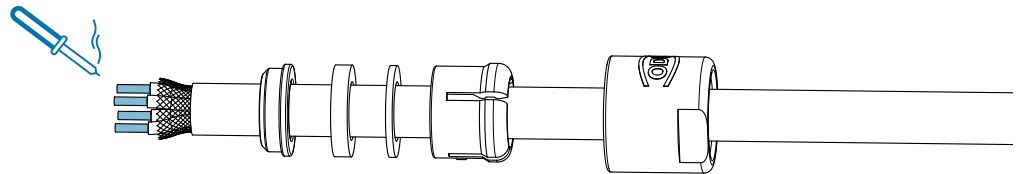

Step 4

- ▶ Solder the **wires** according to contact arrangement.

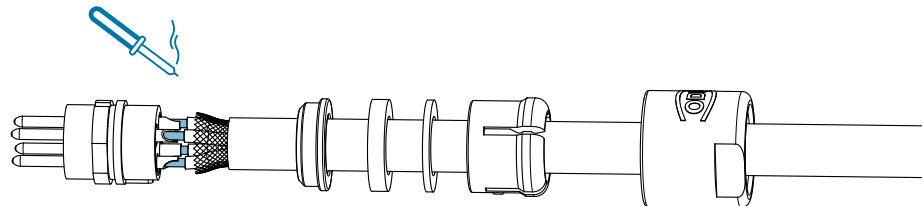

Step 5

- ▶ Bend cable shield outwards, assemble half shells.

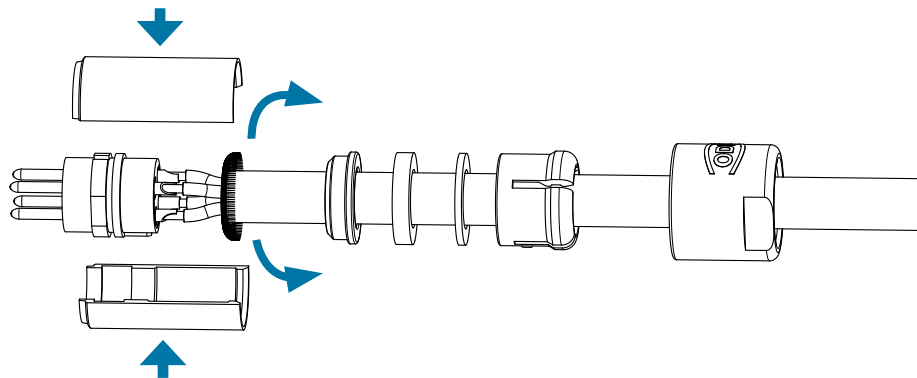

Step 6

- ▶ Slide the cable collet, washer, sealing and EMI ring against the half-shells and clamp the **shield** (A) between it.

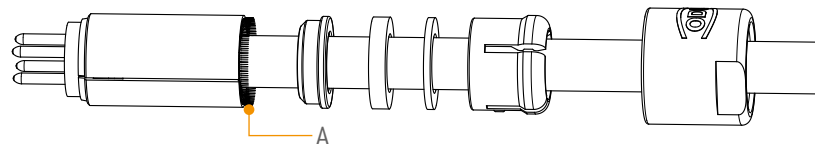

Step 7

- ▶ Insert the complete assembly into the connector housing while respecting the **guidings** (B). If necessary, secure **thread** (C) with adhesive ([see page 04](#)).

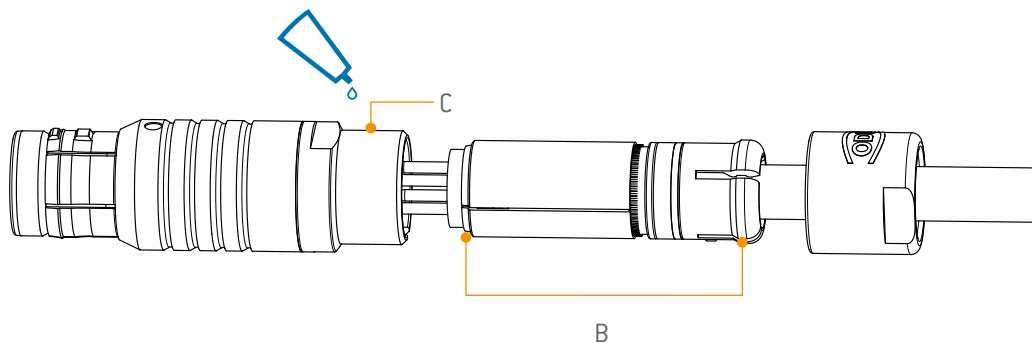

Step 8

- ▶ Screw back nut on the assembled plug, counterhold by means of the **torque wrench** and hold against with ODU spanner wrench.

ATTENTION!

Consider tightening torque ([see page 04](#)).

The assembly is finished.

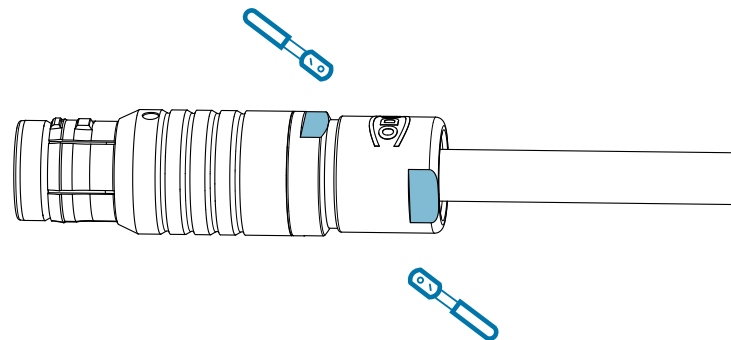

Overview series B right angled plug

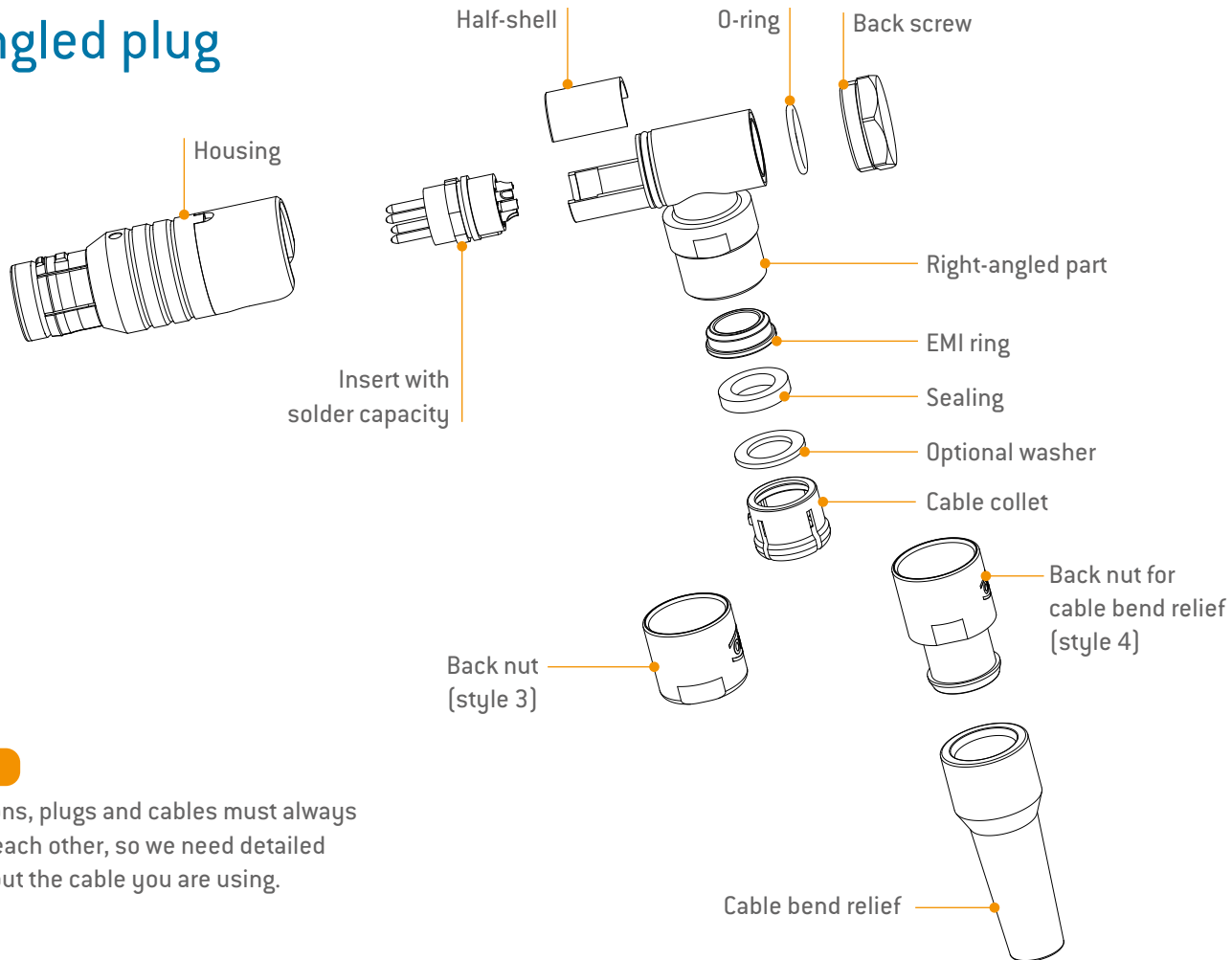

ATTENTION!

In sealed versions, plugs and cables must always be matched to each other, so we need detailed information about the cable you are using.

Assembly of series B right-angled plug

Step 1

- ▶ Slide back nut, cable collet, washer, sealing, EMI ring, right-angled part (and possibly cable bend relief) over the cable.

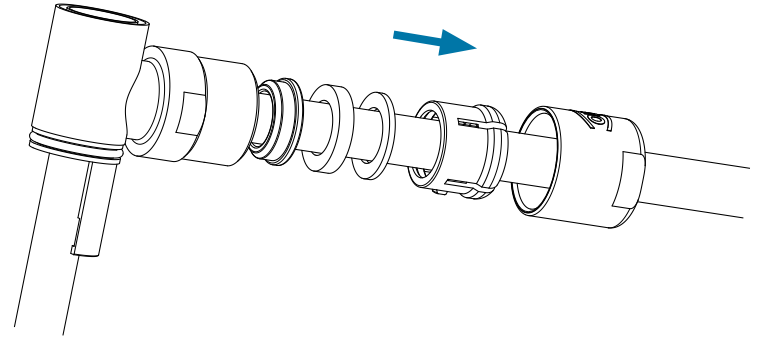

Step 2

- ▶ Strip cable and wire according to reference table ([see page 03](#)).

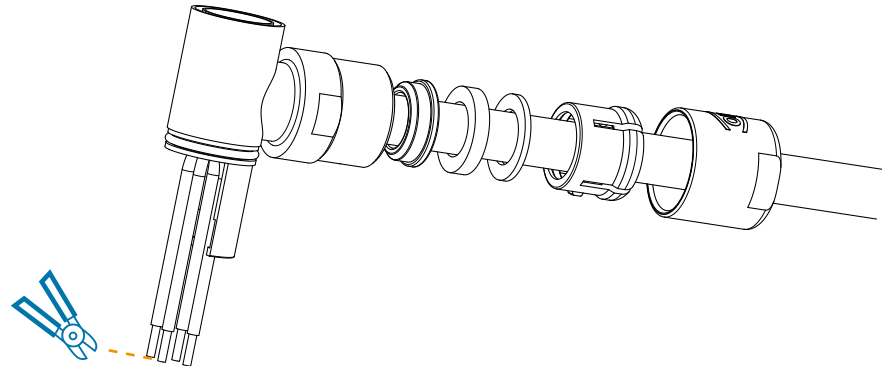

Step 3

► Pre-tin **strands**.

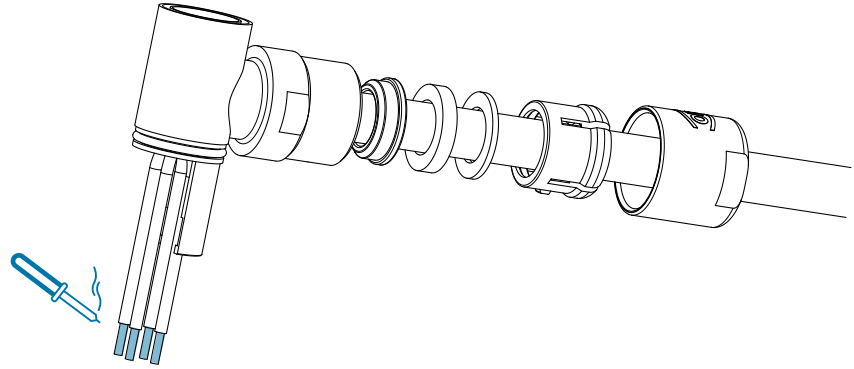

Step 4

► Solder the **wires** according to contact arrangement.

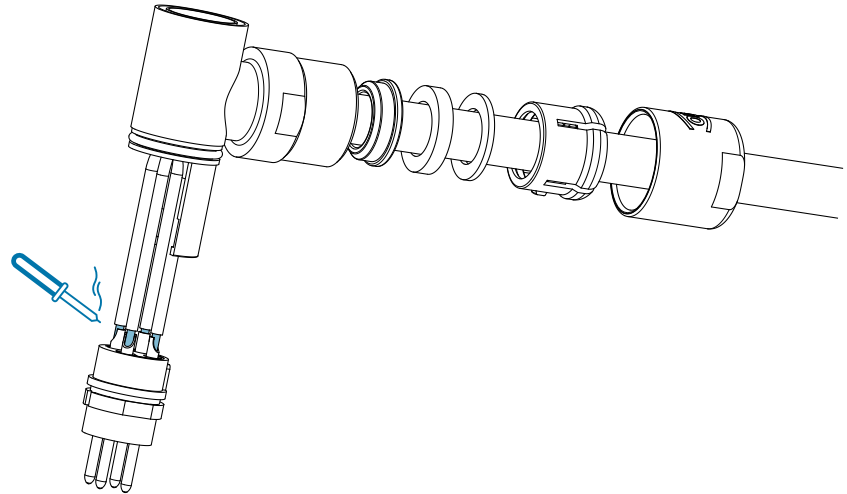

Step 5

- ▶ Pull cable back and spread the **cable shield** [A] over the EMI ring.
Slide half-shell over insulator.
If necessary, secure **thread** [B] with adhesive ([see page 04](#)).

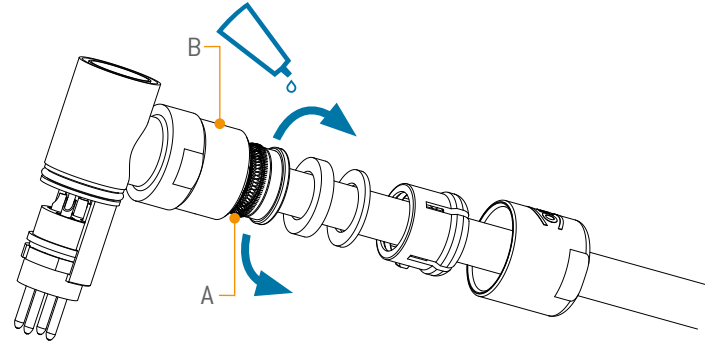

Step 6

- ▶ Slide the cable collet, washer, sealing and EMI ring against the right-angled part and clamp the shield between it.
Screw **back nut** [C] on the right-angled part and hold against with the ODU **torque wrench** [D].

ATTENTION!

Consider tightening torque ([see page 04](#)).

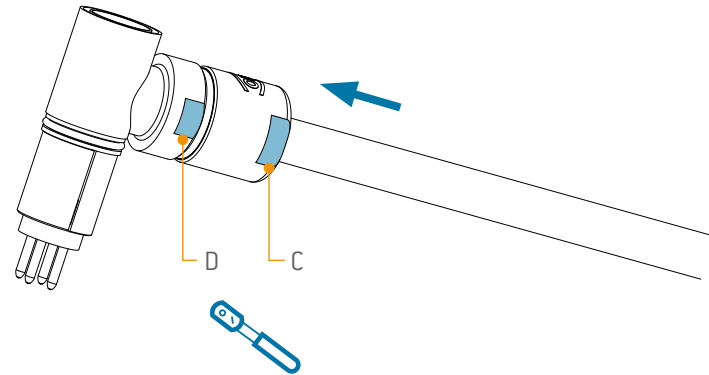

Step 7

- ▶ Insert the complete assembly into the connector housing while respecting the **guidings** (E).
Screw back screw on the right-angled part, if necessary, secure **thread** (F) with adhesive ([see page 04](#)).

ATTENTION! Consider tightening torque ([see page 04](#)).

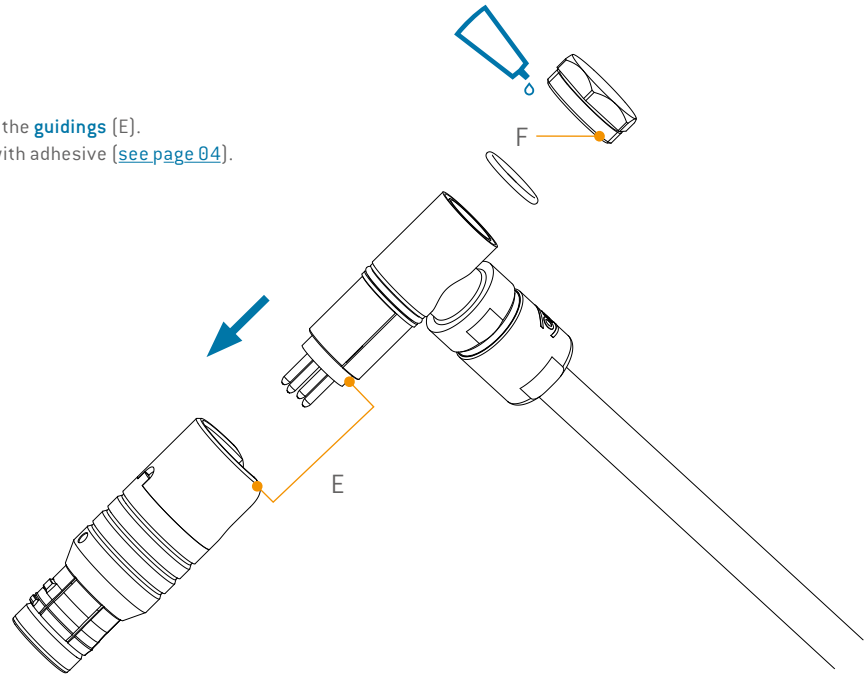

Step 8

- ▶ Mount back screw on the assembled plug and counterhold by means of the **spanner** at (G) with ODU spanner wrench.

ATTENTION! Consider tightening torque ([see page 03](#)).

The assembly is finished.

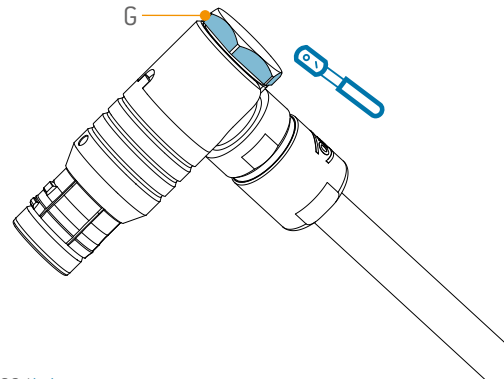



Printed on certified
recycled paper.

All dimensions are in mm.
Some figures are for illustrative purposes only. Subject to change
without notice. Errors and omissions excepted. We reserve the right to
change our products and their technical specifications at any time in
the interest of technical improvement. This publication supersedes all
prior publications.

D00026549 | REV. 5

This publication is also available as a PDF file that can be downloaded
from www.odu-connectors.com